



### APPLICATION

Explosion protected grounding and grounding control device type GGCD-01/.. together with clamp make active grounding system for static grounding and permanent monitoring is intended for use in places with an explosive gas and dust atmosphere. The GGCD is designed for use in the industrial areas and facilities, indoor and outdoor spaces.

Explosion protected grounding and grounding control device type GGCD-01/.., intended for the permanent removal of electrostatic charge that may occur during filling or emptying tanks (road tanks, railcar tanks, barrels). The system provides the conditions for starting the production process only if the insured continuity control loop earthing resistance and jaw of clamp for grounding.

### CONSTRUCTION

Enclosure: polyester plastic reinforced with glass fiber, color - black

Cover: with integrated Thermoplastic elastomer gasket, closes with four M6 stainless steel screws.

### TECHNICAL DATA

Certificate:	Ex CESI 11 ATEX 041
Marking:	CE 0722
Apparatus category:	II 2G
Marking of explosion protection:	Ex d e [ib] mb IIC T5 Gb
Ambient temperature:	-20 °C ≤ T <sub>a</sub> ≤ +50 °C
Degree of protection:	IP 66 category 1
Resistance to shock:	IK 08
Protection class:	I (protective earthing)
Rated voltage:	230V ± 10%
Rated current:	50 mA
Frequency:	50Hz
Output circuit:	2 NO/NC U <sub>n</sub> =250 V AC, I <sub>n</sub> =8 A / 230 V, 4 A at cosφ=0.4
Push button START:	Starting the system, control the time about 10s
Signal lamps:	<b>Red:</b> blinking inside control time (10 sec - MOD2), contacts NO are open, contacts NC are closed, continuous operation (MOD1 and MOD 2), contacts NO are open, contacts NC are closed <b>Green:</b> continuous operation (MOD1 and MOD 2), contacts NO are closed, contacts NC are open
Cable entries:	3 x M25 - power supply, two output circuit 4 x M25 - 2x connection clamp, 2x wire to equipotential busbar or grounding
Weight:	6 kg (without clamp and cable) weight of clamps with 10 m cable ca. 2,5 kg

### MOUNTING

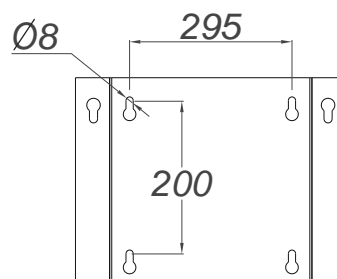

# GGCD

**MODEL CODE**
**DIMENSION**

TYPE	DESCRIPTION:
GGCD-01/K1	Type with one a clamp K1 with 10m spiral cable
GGCD-01/K2	Type with two clamps K1 with 2x10m spiral cable

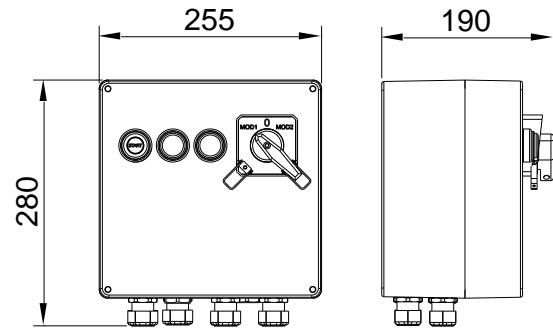
**ACCESSORIES:**

1. Cable reel - 20m with plugs for connection to GGCD
2. Metal cable glands for armoured cable Ex e II
3. Dislocated monitoring system

**Principle of work for GGCD-01/..**

indication on the device	response device
	Clamps are not connected <ul style="list-style-type: none"> <li>• bright red light</li> <li>• disabled transport</li> </ul>
	Clamps are short-circuited with the earthing construction (for example, the iron fence) <ul style="list-style-type: none"> <li>• bright red light</li> <li>• disabled transport</li> </ul>
	Tank is connected via the device GGCD-01 <ul style="list-style-type: none"> <li>• bright green light</li> <li>• transport allowed</li> </ul>
	Tank is connected via the device GGCD-01 but cable to the grounding or busbar is broken <ul style="list-style-type: none"> <li>• bright red light</li> <li>• disabled transport</li> </ul>
	Tank is connected via the device GGCD-01 + successively ground through, for example, "loading arm" <ul style="list-style-type: none"> <li>• bright green light</li> <li>• transport allowed</li> </ul>

